

Duraline®

Micro 518 Connector 100 AMP Test Report

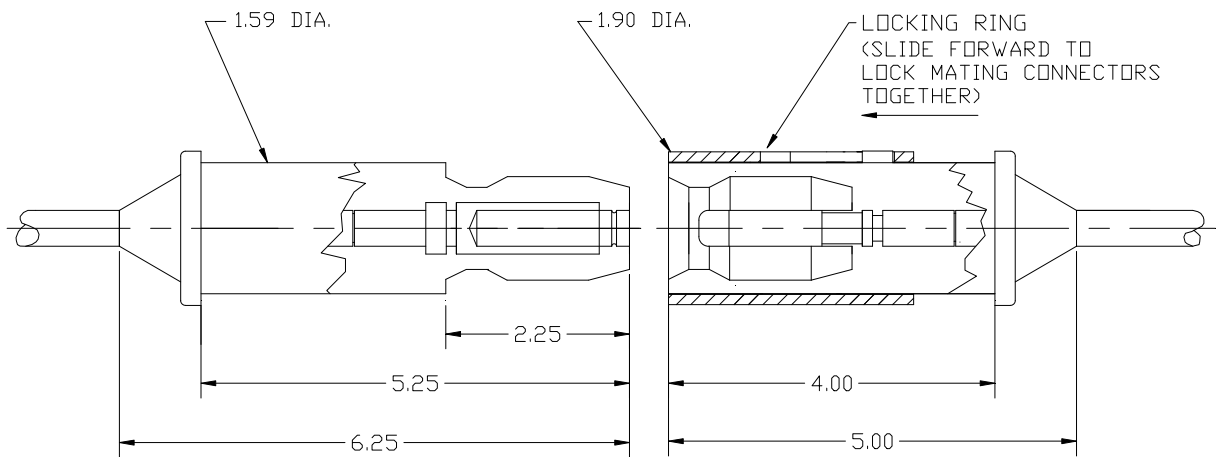

Table of Contents

	Page
Insulation Resistance/Water Immersion Test.....	2
Hi-Potential Dielectric Withstand Voltage Test.....	3
Ampacity Test.....	4
Overload Test.....	5
Destructive Amperage Test.....	6
24 Hour Cycled Load Test.....	7
Retention Test.....	8
Test Report Certifications.....	9
Duraline 518 Press Release.....	10

Duraline®

DIVISION OF J. B. NOTTINGHAM & CO. INC.
75 HOFFMAN LANE ISLANDIA, NEW YORK 11749
TELEPHONE: 631-234-2002
FAX: 631-234-2360

518 Micro Series Connector

1. Insulation Resistance/Water Immersion

A. Equipment Required

1. Water container approximately 30 inches square with walls for 36 inch immersion depth.
2. 500 Volt megohm tester.

B. Test Procedure

1. Mate connectors and lock using locking ring.
2. Immerse connectors with blunt ends of cable dry and above surface of water.
3. Measure leakage resistance from cable to surrounding water.
4. After 24 hrs, measure leakage resistance again.

C. Results

1. Minimum acceptable leakage resistance is 1 megohm from cable conductor to water in both B-3 and B-4.

B-3 INF. By L.W.S. III Date 1/15 -1/16/96

B-4 INF. By L.W.S. III Date 1/15 -1/16/96

Conclusion - No leakage observed.

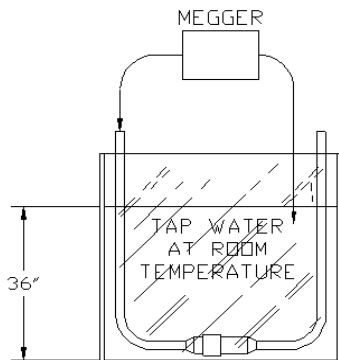

WATER IMMERSION TEST
518 SERIES
SK012496-1

518 Micro Series Connector

2. Hi-Potential Dielectric Withstand Voltage

A. Equipment required

1. Calibrated high voltage tester with voltage and current meters.
2. Metal foil wrapped to form close fitting grounding potential electrode.
3. Corona suppressing caps for blunt cable ends.

B. Test procedure

1. Mate and lock connector pair.
2. Cap blunt ends of cable.
3. Wrap foil around mated connector bodies and connect to ground lead.
4. Connect high voltage probe to one cable end.
5. Engage high voltage and raise voltage level to 9500VAC at a rate of approximately 750 volts/Sec.
6. Read and record leakage current at 9500V.
7. Maintain 9500V for 1 minute. Read and record results.
8. After 1 minute, reduce voltage, at approximately 750 volts/sec, to zero.

C. Results

1. Leakage current of B-6, corrected for losses in connecting cables, must not exceed 0.5 milliampere.

B-6 .42 By L.W.S. III Date 2/8/96

B-7 .42 By L.W.S. III Date 2/8/96

Conclusion - No damage to connectors or cable.

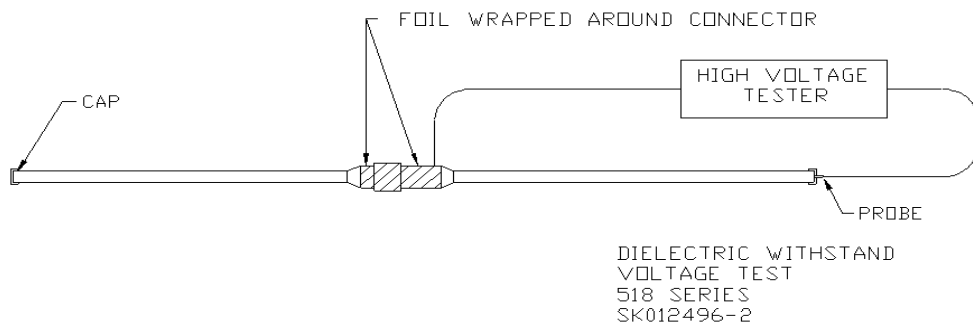

518 Micro Series Connector

3. Ampacity

A. Equipment required

1. Low voltage high current source with meter.
2. Thermocouples and temperature gauge.
3. Millivolt meter.

B. Test procedure

1. Terminate cable with appropriate lugs.
2. Provide access to cable conductors and contacts at T1, T2, mv1 and mv2 locations (in accordance with sketch below), to allow measurements to be taken. Thermocouple and millivolt probes should not enter or interfere with conductive barrel.
3. Mate and lock connectors.
4. Attach lugs to current source.
5. Turn on source and raise current level to 100 amperes (rating of connector).
6. Read and record connector, cable and ambient room temperature every 30 minutes until connector temperature rise above ambient temperature remains constant for 60 minutes.
7. Read and record millivolts across connector and across equivalent length of cable.

C. Results at rated amperage

Note: Temperature difference of B-6 must not exceed 54 deg F between ambient and connector.

B-6a - Temperature rise of connector over ambient 29 deg F By T.P.
B-6b - Temperature rise of cable over ambient 29 deg F Date 2/20/96

B-7a - Millivolt drop across connector 20 mv By T.P.
B-7b - Millivolt drop across equivalent length of cable 15 mv Date 2/20/96

Conclusion - There was no degradation or deterioration of the connectors when tested at rated ampacity.

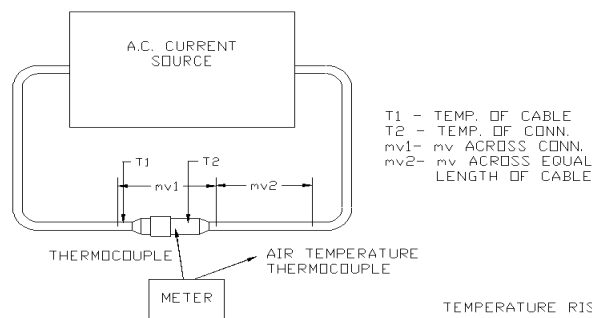

TEMPERATURE RISE
AND MILLIVOLT DROP TESTS
518 SERIES
SK012496-3

518 Micro Series Connector

4. Overload Test

A. Equipment required

1. Low voltage high current source with meter.
2. Thermocouples and temperature gauge.
3. Millivolt meter.

B. Test procedure

1. Terminate cable with appropriate lugs.
2. Provide access to cable conductors and contacts at T1, T2, mv1 and mv2 locations (in accordance with sketch below), to allow measurements to be taken. Thermocouple and millivolt probes should not enter or interfere with conductive barrel.
3. Mate and lock connectors.
4. Attach lugs to current source.
5. Turn on source and raise current level to 133 (33 1/3% over the amperage rating of the connector).
6. Read and record connector, cable and ambient room temperature before and after 10 minutes of continuous load.
7. Read and record millivolts across connector and across equivalent length of cable.

C. Results at overload amperage of 133 amperes.

Note: Temperature difference of B-6 must not exceed 54 deg F between ambient and connector.

B-6a - Temperature rise of connector over ambient 16 deg F By T.P.
B-6b - Temperature rise of cable over ambient 23 deg F Date 2/21/96

B-7a - Millivolt drop across connector 26 mv By T.P.
B-7b - Millivolt drop across equivalent length of cable 21 mv Date 2/21/96

Conclusion - There was no degradation or deterioration of the connectors when tested at 33 1/3% overload for 10 minutes.

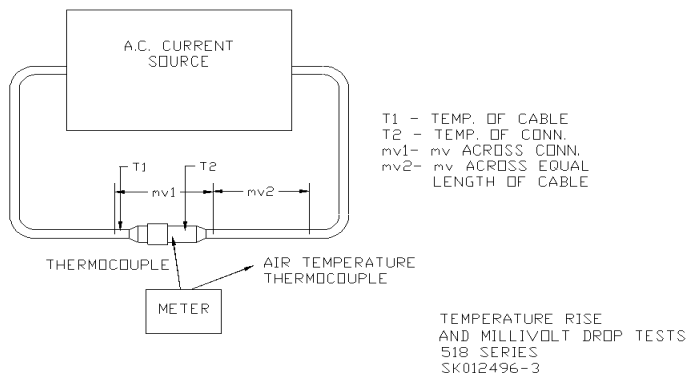

518 Micro Series Connector

5. Destructive Amperage Test

A. Equipment required

1. Low voltage high current source with meter.
2. Thermocouples and temperature gauge.
3. Millivolt meter.

B. Test procedure

1. Terminate cable with appropriate lugs.
2. Provide access to cable conductors and contacts at T1, T2, mv1 and mv2 locations (in accordance with sketch below), to allow measurements to be taken. Thermocouple and millivolt probes should not enter or interfere with conductive barrel.
3. Mate and lock connectors.
4. Attach lugs to current source.
5. Turn on source and raise current level to 140 amperes (40% over the amperage rating of the connector).
6. Read and record connector, cable and ambient room temperatures periodically and at the conclusion of a continuous 24 hours of testing.
7. Read and record millivolts across connector and across equivalent length of cable.

C. Results at destructive overload amperage of 140 amperes.

B-6a - Temperature rise of connector over ambient 54 deg F By T.P.
B-6b - Temperature rise of cable over ambient 56 deg F Date 2/20/96

B-7a - Millivolt drop across connector 29 mv By T.P.
B-7b - Millivolt drop across equivalent length of cable 23 mv Date 2/20/96

Conclusion - There was no degradation or deterioration of the connectors when tested at 40% overload for 24 hours.

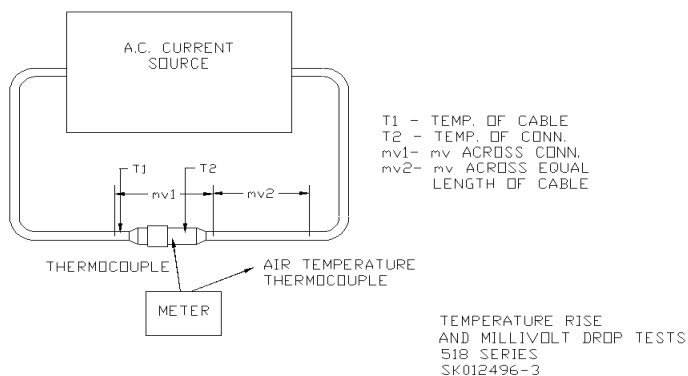

6. 24 Hour Cycled Loading Test - 518 Micro Series Connector

A. Equipment required

1. Low voltage high current source with meter.
2. Thermocouples and temperature gauge.
3. Millivolt meter.
4. Electronic Time Control Device

B. Test procedure

1. Terminate cable with appropriate lugs.
2. Provide access to cable conductors and contacts at T1, T2, mv1 and mv2 locations (in accordance with sketch below), to allow measurements to be taken. Thermocouple and millivolt probes should not enter or interfere with conductive barrel.
3. Mate and lock connectors.
4. Attach lugs to current source.
5. Set electronic time control device to provide a cycled load to the connector (25 minutes on, 10 minutes off), over a continuous 24 hour period.
5. Turn on source and raise current level to 100 amperes (connector rating).
6. Read and record connector, cable and ambient room temperatures periodically and at the conclusion of 24 hours of testing.
7. Read and record millivolts across connector and across equivalent length of cable periodically and at the conclusion of 24 hours of testing.

C. Results of cycled load test at 100 amperes.

B-6a - Temperature rise of connector over ambient 24 deg F By T.P.
 B-6b - Temperature rise of cable over ambient 28 deg F Date 2/22/96

B-7a - Millivolt drop across connector 20 mv By T.P.
 B-7b - Millivolt drop across equivalent length of cable 17 mv Date 2/22/96

Conclusion - There was no degradation or deterioration of the connectors when tested at a cycled load of 100 amperes for 24 hours.

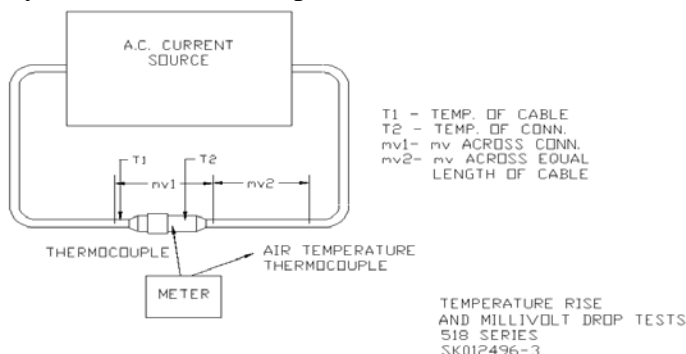

518 Micro Series Connector

7. Retention

A. Equipment required

1. Securely anchored vise.
2. Spring scale (to approx. 500 lbs) with attached hook.
3. Lever.
4. Worm drive clamp.
5. Heavy wire loop.

B. Test Procedure

1. Clamp pigtail lead from one connector half in vise.
2. Attach wire loop to other pigtail with worm drive clamp.
3. Mate connectors - do not lock.
4. Pull with spring scale until disconnected - note scale reading.
5. Mate connectors and lock.
6. Pull with spring scale (using lever) until disconnected.

C. Results

1. Scale reading of B-4 should be within the range 30-60 lb.
2. The locked connector shall not disconnect with a pull force of less than 90 lbs.

Any motion due to elastic distortion shall reverse with removal of pull force.

Insertion force	35 lbs. (approx)
Withdrawal force (unlocked)	35 lbs.
Retention (locked)	98 lbs.

B-4 35 lbs. By T.P. Date 1/16/96

B-6 98 lbs. By T.P. Date 1/16/96

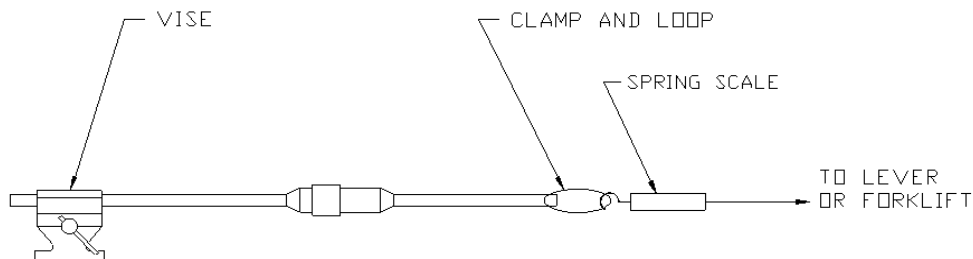

RETENTION TEST
518 SERIES
SK012496-4



518 Micro Series Connector

*****NOTE*****

THE TEST INFORMATION ,PROCEDURE, AND RESULTS CONTAINED IN THIS REPORT, DATED APRIL 1, 1996, AND COMPRISED OF PAGES 1 of 8 THROUGH 8 of 8 HAVE BEEN APPROVED AND WITNESSED BY:

QC Manager L.W.S. III Operations Manager J.S.

Engineering Manager T.P. General Manager C.S.

The connectors tested in this report were molded to #4 DLO cable . These connectors were tested to be rated 100A, 4160 V.A.C..



DIVISION OF J. B. NOTTINGHAM & CO. INC.
75 HOFFMAN LANE ISLANDIA, NEW YORK 11749
TELEPHONE: 631-234-2002
FAX: 631-234-2360

Duraline Press Release

DURALINE INTRODUCES UNIQUE "QUICK" CONNECTORS

Islandia, NY, March, 1985 - Duraline, Division of J.B. Nottingham and Co., Inc., has announced the availability of its novel Series 518SR and 518Jr connectors and receptacles. An innovative 360 degree non- oriented positive locking collet design allows the Series 518 connector pair to be mated and locked without regard to specific orientation. There is no cam or keyway to line up in position. Thus, the Series 518 connectors and receptacles are ideal for use by utilities during scheduled outages for maintenance on large residual heat pump motors and wherever else other large motors (250-400 HP and up) may require fast change-outs. DURALINE'S new series offers the direct advantage of quick, efficient and economical connections, as opposed to the current "hard wired" method, which is labor intensive and time consuming.

There are several other benefits inherent in DURALINE'S Series 518 connector. It can optionally feature the use of all nuclear radiation-resistant materials, which enable the connector to be used in nuclear - fueled power plants. Since these crews must work under limited allowable time exposures, the quick connection properties of the Series 518 connector are quite desirable. Also, the mated pair is fully watertight, suiting it to areas which are generally hosed down with water under high pressure as part of clean-up procedure. The series 518 maximum rating is 1000 amperes at 5kv for continuous service. It may also be color coded for phase identification.

For further information, write to DURALINE, Division of J.B. Nottingham and Co. Inc., 75 Hoffman Lane, Islandia, NY 11749.