

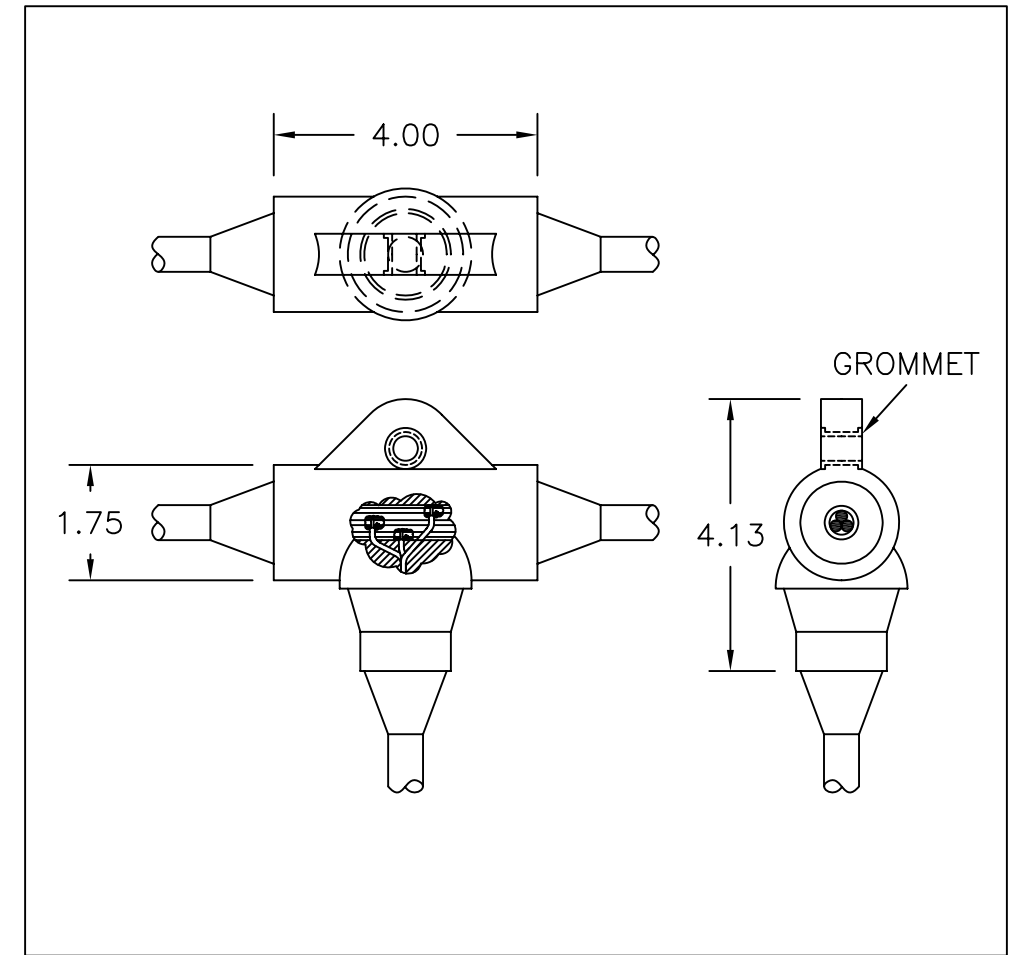

THIS DRAWING/SPECIFICATION CONTAINS PROPRIETARY INFORMATION OF THE J.B. NOTTINGHAM AND CO., INC./DURALINE, WHICH SHALL NOT BE PUBLISHED, REPRODUCED, COPIED, FURTHER DISCLOSED AS THE BASIS OF MANUFACTURE FOR OR SALE OF APPARATUS TO OTHERS THAN THE J.B. NOTTINGHAM AND CO., INC., EXCEPT BY WRITTEN PERMISSION OF A DULY AUTHORIZED REPRESENTATIVE OF SAID COMPANY.

| REVISIONS |     |             |      |          |
|-----------|-----|-------------|------|----------|
| ZONE      | REV | DESCRIPTION | DATE | APPROVED |
|           |     |             |      |          |

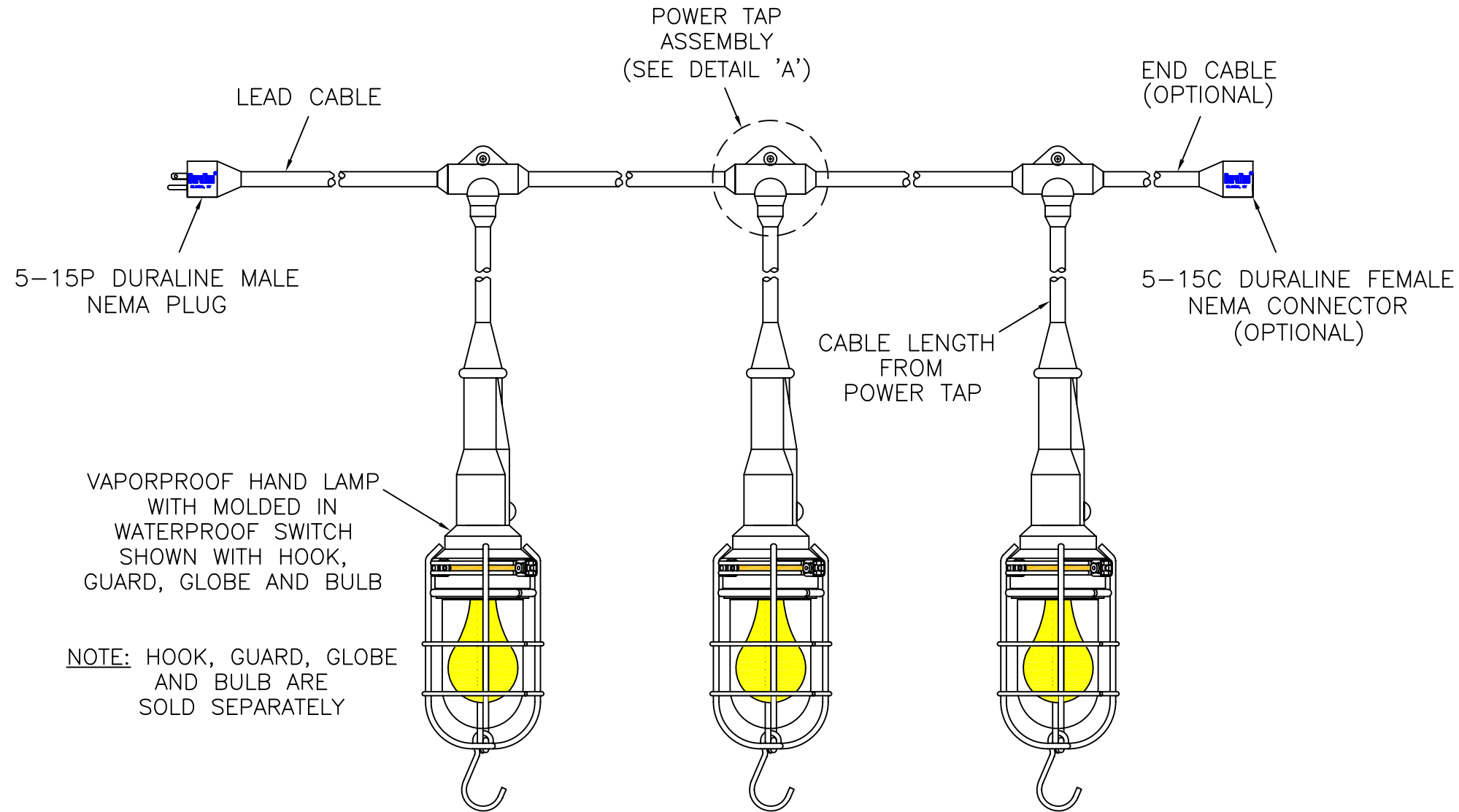

DETAIL 'A'

NOTE: HOOK, GUARD, GLOBE AND BULB ARE SOLD SEPARATELY

|  |      |   |  |        |   |
|--|------|---|--|--------|---|
| DIMENSIONS IN INCHES UNLESS OTHERWISE NOTED. TOLERANCES: |      | Wet Location Stringlight with "T" Drops and Vaporproof Hand Lamps |  |        |   |
| FRAC.  | DEC. | ANG.  |  DIV. OF J.B. NOTTINGHAM<br>75 HOFFMAN LANE<br>ISLANDIA, NY 11749 |        |   |
| MATERIAL: MOLDED BODIES ARE HYPALON                      |      |   |  |        |   |
| FINISH :   |      |   | DRAWN DR   | 2/1/07 | SIZE A<br>FSCM NO. 16998<br>DWG. NO. WLSWTDNVP HL<br>REV. |
| DO NOT SCALE DRAWING                                     |      |   | CHECKED  | ISSUED |   |
|  |      |   | SCALE  |        | SHEET 1 OF 1  |