

THIS DRAWING/SPECIFICATION
CONTAINS PROPRIETARY
INFORMATION OF THE J.B
NOTTINGHAM AND CO., INC.,
DURALINE, WHICH SHALL NOT BE
PUBLISHED, REPRODUCED, COPIED,
FURTHER DISCLOSED AS THE
BASIS OF MANUFACTURE FOR
OR SALE OF APPARATUS TO
OTHERS THAN THE J.B.
NOTTINGHAM AND CO., INC.,
EXCEPT BY WRITTEN PERMISSION
OF A DULY AUTHORIZED
REPRESENTATIVE OF SAID
COMPANY.

| REVISIONS | | | |
|-----------|-------------|------|----------|
| REV. | DESCRIPTION | DATE | APPROVED |
| | | | |

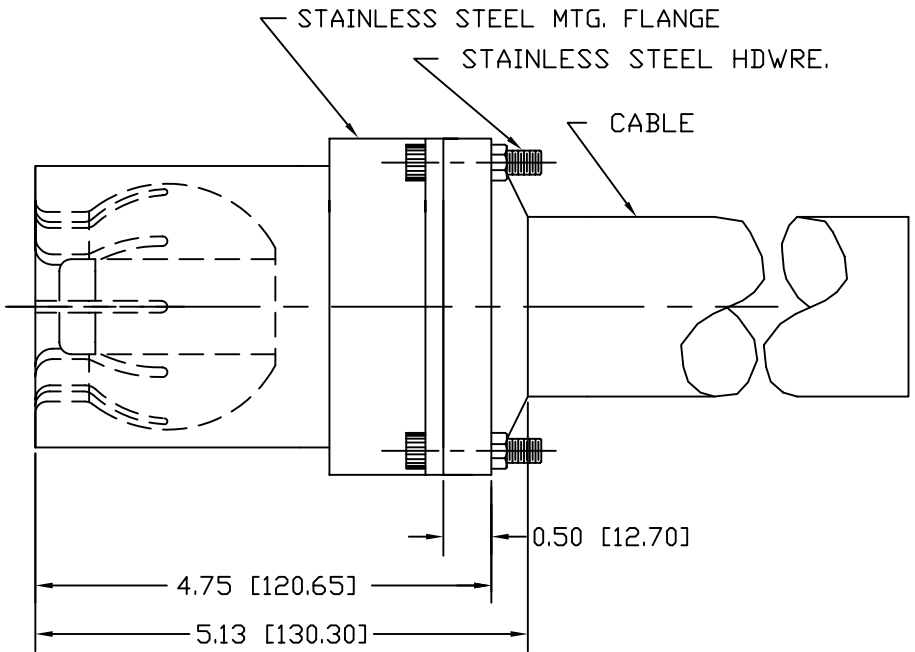
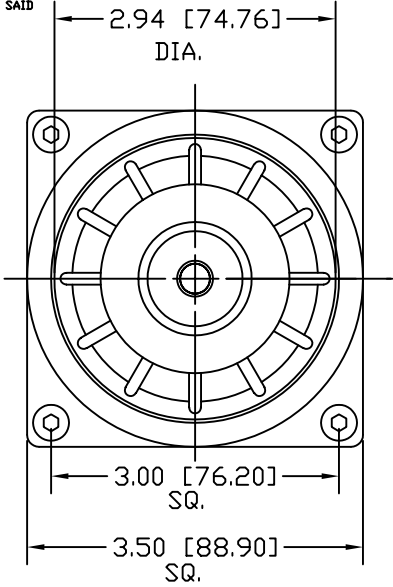

NOTE:
1) DIMENSIONS SHOWN IN BRACKETS
ARE IN MM.

| | | | | | |
|--|------|------------------------|------------|----------|---|
| DIMENSIONS IN INCHES UNLESS OTHERWISE NOTED. TOLERANCES: | | 518 SR MALE RECEPTACLE | | | |
| FRAC. | DEC. | ANG. | APPROVALS | DATE | DURALINE DIV. J.B. NOTTINGHAM 75 HOFFMAN LANE ISLANDIA, NY 11749 |
| MATERIAL BODY IS | | | DRAWN T.P. | 11/4/94 | |
| FINISH: | | | CHECKED | ISSUED | SIZE A |
| DO NOT SCALE DRAWING | | | DR | 11/24/03 | FSCM NO. 16998 |
| | | | | | DWG. NO. SM151834 |
| | | | | | REV. |
| | | | | | SHEET 1 OF 1 |